

## Serie 6RXSP

### Electrobombas sumergibles para pozos de 6" de diámetro, construidas totalmente en acero inoxidable AISI 304 o AISI 316.

Alcanzan óptimos rendimientos hidráulicos. Son de máxima resistencia a la abrasión y corrosión.

#### Especificaciones Técnicas

- Caudal: hasta 78 m<sup>3</sup>/h.
- Altura de elevación: hasta 430 m.
- El líquido bombeado debe ser limpio y estar libre de sustancias abrasivas, compatible con los componentes y materiales de la bomba.
- Su diseño de vanguardia y tecnología de avanzada permiten alcanzar óptimos rendimientos hidráulicos y eléctricos.
- El cuerpo hidráulico es totalmente de acero inoxidable AISI 304.
- Por su robustez, tienen una larga vida útil de trabajo duro y continuo.
- Son altamente eficientes gracias a sus estrictos estándares y a sus características constructivas.
- Cuentan con válvula de retención de acero inoxidable.
- Máxima temperatura del líquido: 30°C.
- Máxima presencia de arena: 50 g/m<sup>3</sup>.
- Boca de salida roscada de Ø 2½", 3" y 4" según el modelo.
- Equipadas con motores de 1,5 a 60 HP, de 4" y 6" en arranque directo o estrella-triángulo.

#### Materiales

- Con cuerpo hidráulico totalmente de acero inoxidable AISI 304: impulsores, difusores, carcasa exterior, cuerpos de aspiración y descarga, y fleje de protección.
- Eje de acero inoxidable pulido AISI 431.
- Boca de descarga de acero inoxidable con válvula de retención para una fácil instalación y una mayor durabilidad.
- Cojinete axial de NBR que asegura una baja fricción y una alta resistencia.
- Rejilla de succión de acero inoxidable que impide la entrada de arena y otras sustancias.
- Bujes de goma tipo Goodrich y casquillos de acero inoxidable AISI 304.
- Brida de acople Nema.
- Cuellos de impulsor en acero inoxidable/ NBR. Manchón rígido estriado en acero inoxidable AISI 304.



- Abastecimiento de agua en hogares y emprendimientos edilicios.
- Sistemas de riego.
- Sistemas anti-incendio.
- Drenaje y desagote en minas.

#### Diagrama de Dimensiones

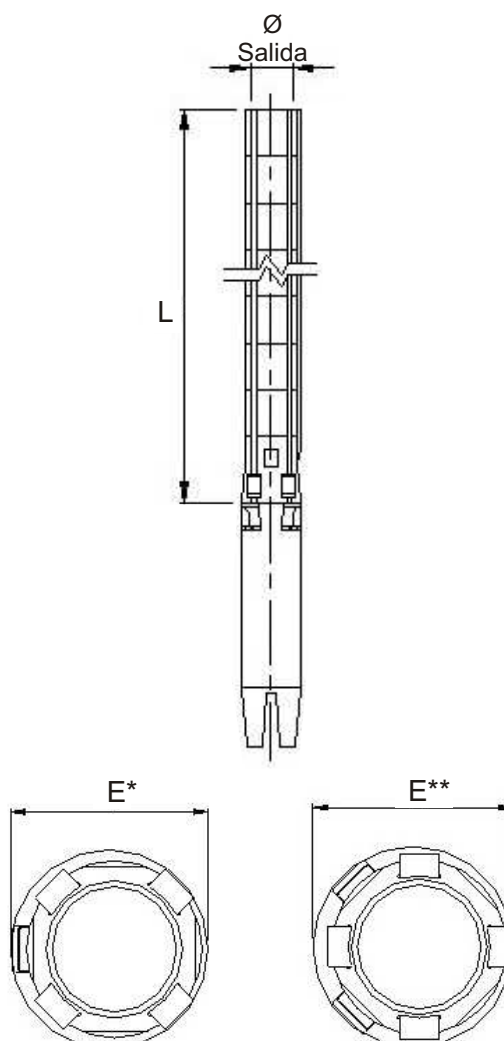

## Tablas de dimensiones

Modelo de bomba	L (mm)	Ø Salida	E* (mm)	E** (mm)	Peso Bomba (Kg)
6RXSP 80-40	2070	2 1/2"	142		48.8
6RXSP 90-1	343	2 1/2"	131		5
6RXSP 90-2	403	2 1/2"	131		6.4
6RXSP 90-4	524	2 1/2"	131		9.3
6RXSP 90-5	585	2 1/2"	131		10.8
6RXSP 90-6	645	2 1/2"	131		12.2
6RXSP 90-7	706	2 1/2"	131		13.7
6RXSP 90-10	887	2 1/2"	131		18
6RXSP 90-13	1069	2 1/2"	142	142	22.4
6RXSP 90-17	1311	2 1/2"	142	142	28.2
6RXSP 90-20	1492	2 1/2"	142	142	32.5
6RXSP 90-22	1613	2 1/2"	142	142	35.4
6RXSP 90-24	1734	2 1/2"	142	142	38.3
6RXSP 90-27	1916	2 1/2"	142	142	42.7
6RXSP 90-29	2037	2 1/2"	142	142	45.6
6RXSP 90-31	2158	2 1/2"	142	142	48.5
6RXSP 90-33	2279	2 1/2"	142	142	51.4
6RXSP 90-36	2460	2 1/2"	142	142	55.7
6RXSP 90-38	2581	2 1/2"	142	142	58.6
6RXSP 90-40	2702	2 1/2"	142	142	61.5
6RXSP 135-19	1979	3"	142		41.5
6RXSP 135-28	2789	3"	142		58.7
6RXSP 135-36	3509	3"	142		73.9
6RXSP 150-2	462	3"	131		8.4
6RXSP 150-3	558	3"	131		10.1
6RXSP 150-4A	654	3"	131		11.8
6RXSP 150-4	654	3"	131		11.8
6RXSP 150-5	750	3"	131		13.5
6RXSP 150-6	846	3"	131		15.2
6RXSP 150-7	942	3"	142	142	16.9
6RXSP 150-8	1038	3"	142	142	18.6
6RXSP 150-9	1134	3"	142	142	20.3
6RXSP 150-10	1230	3"	142	142	22
6RXSP 150-11	1326	3"	142	142	23.6
6RXSP 150-12	1422	3"	142	142	25.3
6RXSP 150-13	1518	3"	142	142	27
6RXSP 150-16	1806	3"	142	142	32.1
6RXSP 150-17	1902	3"	142	142	33.8
6RXSP 150-18	1998	3"	142	142	35.5
6RXSP 150-19	2094	3"	142	142	37.2
6RXSP 150-20	2190	3"	142	142	38.9
6RXSP 150-21	2286	3"	142	142	40.6
6RXSP 150-22	2382	3"	142	142	42.3
6RXSP 150-23	2478	3"	142	142	44
6RXSP 150-24	2574	3"	142	142	45.6
6RXSP 150-25	2670	3"	142	142	47.3
6RXSP 150-26	2766	3"	142	142	49
6RXSP 150-27	2862	3"	142	142	50.7
6RXSP 150-28	2958	3"	142	142	52.4
6RXSP 150-29	3054	3"	142	142	54.1
6RXSP 150-30	3150	3"	142	142	55.8
6RXSP 150-31	3246	3"	142	142	57.5
6RXSP 150-32	3342	3"	142	142	59.2
6RXSP 150-33	3438	3"	142	142	60.9
6RXSP 150-34	3534	3"	142	142	62.6
6RXSP 150-35	3630	3"	142	142	64.3

Modelo de bomba	L (mm)	Ø Salida	E* (mm)	E** (mm)	Peso Bomba (Kg)
6RXSP 220-18	2979	3 1/4"	1150		43,8
6RXSP 230-2	496	3 1/4"	146		9,2
6RXSP 230-3C (4")	609	3 1/4"	146		11,5
6RXSP 230-3 (6")	609	3 1/4"	146		11,5
6RXSP 230-4	722	3 1/4"	146		13,8
6RXSP 230-5	835	3 1/4"	149	152	16
6RXSP 230-7	1061	3 1/4"	149	152	20,6
6RXSP 230-8C	1174	3 1/4"	149	152	22,9
6RXSP 230-9	1287	3 1/4"	149	152	25,2
6RXSP 230-10	1400	3 1/4"	149	152	27,4
6RXSP 230-11	1513	3 1/4"	149	152	29,8
6RXSP 230-12	1626	3 1/4"	149	152	32
6RXSP 230-13	1739	3 1/4"	149	152	34,2
6RXSP 230-14	1852	3 1/4"	149	152	36,5
6RXSP 230-15	1965	3 1/4"	149	152	38,8
6RXSP 230-16	2078	3 1/4"	149	152	41
6RXSP 230-17	2191	3 1/4"	149	152	43,4
6RXSP 230-18	2304	3 1/4"	149	152	45,6
6RXSP 230-19	2417	3 1/4"	149	152	47,9
6RXSP 230-20	2530	3 1/4"	149	152	50,1
6RXSP 230-21	2643	3 1/4"	149	152	52,6
6RXSP 230-22	2756	3 1/4"	149	152	54,8
6RXSP 230-23	2869	3 1/4"	149	152	57
6RXSP 230-24	2982	3 1/4"	149	152	59,3
6RXSP 300-1	383	3 1/4"	146		6,9
6RXSP 300-2A	496	3 1/4"	146		9,2
6RXSP 300-2	496	3 1/4"	146		9,2
6RXSP 300-3	609	3 1/4"	146		11,5
6RXSP 300-4	722	3 1/4"	149	152	13,7
6RXSP 300-5	835	3 1/4"	149	152	16
6RXSP 300-6	948	3 1/4"	149	152	18,3
6RXSP 300-8	1174	3 1/4"	149	152	22,9
6RXSP 300-9	1287	3 1/4"	149	152	25,1
6RXSP 300-10	1400	3 1/4"	149	152	27,4
6RXSP 300-11	1513	3 1/4"	149	152	29,7
6RXSP 300-12	1626	3 1/4"	149	152	32
6RXSP 300-13	1739	3 1/4"	149	152	34,3
6RXSP 300-14	1852	3 1/4"	149	152	36,5
6RXSP 300-15	1965	3 1/4"	149	152	38,8
6RXSP 300-16	2078	3 1/4"	149	152	41,1
6RXSP 300-17	2191	3 1/4"	149	152	43,4
6RXSP 300-18	2304	3 1/4"	149	152	45,7
6RXSP 300-19	2417	3 1/4"	149	152	48
6RXSP 300-20	2530	3 1/4"	149	152	50,2
6RXSP 300-21	2643	3 1/4"	149	152	53
6RXSP 300-22	2756	3 1/4"	149	152	55
6RXSP 300-24	2982	3 1/4"	149	152	59

E\*: Máximo diámetro de bomba con motor de 1 cable.  
E\*\*: Máximo diámetro de bomba con motor de 2 cables.

Tabla de performance. Serie 6RXSP 80-90-135-150-220.

Modelo de bomba	Potencia Motor		Q = Caudal																	Ø Salida			
	Kw	HP	l/min m³/h	50 3	100 6	150 9	200 12	250 15	300 18	350 21	400 24	450 27	500 30	550 33	600 36	650 39	700 42	800 48	900 54		933 56		
6RXSP 80-40	18.5	25		372	362	350	327	290	239	180	108											2½"	
6RXSP 90-1	0.55	0.75		11.5	11	10.5	9.5	8	7	6	4											2½"	
6RXSP 90-2	1.1	1.5		22	21.5	20	19	17.5	14	12	7											2½"	
6RXSP 90-4	2.2	3		42.5	42	40	38	33	28.5	23	16											2½"	
6RXSP 90-5	3	4		53	52	50.5	47.5	42.5	37	28.5	18											2½"	
6RXSP 90-6	3.7	5		64	63	60	56	50	43	34	23											2½"	
6RXSP 90-7	4	5.5		75	74	71	66	59	50.5	40	28											2½"	
6RXSP 90-10	5.5	7.5		108	107	102	95	86	74	58	43											2½"	
6RXSP 90-13	7.5	10		141	139	133	124	112	95	75	51											2½"	
6RXSP 90-17	9	12.5		184	182	175	163	147	126	100	69											2½"	
6RXSP 90-20	11	15		216	213	206	192	173	147	116	81											2½"	
6RXSP 90-22	13	17.5		239	237	228	212	190	163	129	91											2½"	
6RXSP 90-24	13	17.5		260	257	247	230	208	178	140	99											2½"	
6RXSP 90-27	15	20		291	288	277	259	234	200	158	111											2½"	
6RXSP 90-29	18.5	25		314	311	300	279	250	215	170	120											2½"	
6RXSP 90-31	18.5	25		335	330	318	298	269	230	181	127											2½"	
6RXSP 90-33	18.5	25		355	350	337	315	285	243	191	135											2½"	
6RXSP 90-36	22	30		390	385	371	348	313	268	210	146											2½"	
6RXSP 90-38	22	30		410	405	390	365	330	281	222	155											2½"	
6RXSP 90-40	22	30		433	428	412	384	346	296	235	165											2½"	
6RXSP 135-28	22	30		302	297	292	280	268	257	241	224	202	178	150	121							2½"	
6RXSP 135-36	30	40		389	382	375	360	345	330	310	287	260	229	196	159							2½"	
6RXSP 150-2	2.2	3	H = Altura en m		23	22	21	20	19	18	17	16	15	13	11	9	6					3"	
6RXSP 150-3	3	4			33	32	31	30	29	28	26	24	22	20	17	14	11						3"
6RXSP 150-4A	3.7	5			43	42	41	40	38	36	34	31	28	26	23	19	15						3"
6RXSP 150-4	3.7	5			47	46	45	44	42	40	37	34	31	29	25	21	16,5						3"
6RXSP 150-5	5.5	7.5			55	53	52	50	48	45	42	39	36	32	29	25	20						3"
6RXSP 150-6	5.5	7.5			67	64	62	60	58	56	52	49	45	40	36	30	25						3"
6RXSP 150-7	7.5	10			77	75	73	70	68	64	60	57	52	48	41	35	28						3"
6RXSP 150-8	7.5	10			88	87	84	81	78	73	68	64	58	53	46	38	31						3"
6RXSP 150-9	11	15			100	98	96	92	88	82	77	72	66	59	52	45	37						3"
6RXSP 150-10	11	15			111	109	106	102	98	93	88	82	76	68	60	51	42						3"
6RXSP 150-11	11	15			122	120	117	112	108	102	97	90	83	76	67	57	47						3"
6RXSP 150-12	11	15			133	130	127	122	117	112	105	98	90	81	72	61	50						3"
6RXSP 150-13	11	15			143	140	137	132	127	120	113	105	97	87	77	66	55						3"
6RXSP 150-16	15	20			178	176	172	167	159	151	142	132	121	108	96	82	68						3"
6RXSP 150-17	15	20			188	185	180	173	167	158	148	138	127	116	103	88	71						3"
6RXSP 150-18	18.5	25			198	195	190	183	175	166	155	144	133	120	107	91	74						3"
6RXSP 150-19	18.5	25			208	205	199	192	182	172	161	150	137	125	110	94	77						3"
6RXSP 150-20	18.5	25			219	215	209	201	192	182	170	158	144	130	114	97	78						3"
6RXSP 150-21	18.5	25			230	226	220	212	201	190	177	164	149	134	117	100	80						3"
6RXSP 150-22	22	30			241	237	230	221	212	200	188	173	158	142	124	105	85						3"
6RXSP 150-23	22	30		252	247	240	231	222	210	196	182	166	148	130	110	90						3"	
6RXSP 150-24	22	30		258	254	248	240	230	219	207	191	175	156	137	117	93						3"	
6RXSP 150-25	22	30		276	271	264	256	245	232	218	202	186	167	146	122	97						3"	
6RXSP 150-26	22	30		287	282	275	266	255	242	227	212	194	173	152	127	100						3"	
6RXSP 150-27	25.5	35		298	293	286	277	265	252	238	221	202	181	158	132	105						3"	
6RXSP 150-28	25.5	35		308	303	296	288	276	263	247	230	212	190	164	137	110						3"	
6RXSP 150-29	25.5	35		319	314	307	298	287	273	257	240	220	196	170	143	113						3"	
6RXSP 150-30	25.5	35		330	325	318	308	297	282	265	247	227	203	176	148	120						3"	
6RXSP 150-31	25.5	35		342	336	327	317	304	289	273	254	233	210	184	155	125						3"	
6RXSP 150-32	30	40		353	347	338	327	313	298	281	261	240	217	190	160	130						3"	
6RXSP 150-33	30	40		363	358	349	337	323	307	290	270	248	222	196	166	135						3"	
6RXSP 150-34	30	40		375	369	360	348	335	319	301	280	258	232	203	173	142						3"	
6RXSP 150-35	30	40		382	377	368	358	346	329	311	290	267	240	211	180	148						3"	
6RXSP 220-18	22	30			201	199	197	190	183	175	167	159.5	152	143.5	135	127	118	100	75	67		3"	

NOTA. Los modelos 90-10, 150-5, 150-6, 150-7 y 150-8 pueden utilizarse con motores de 4" y de 6".

### Tabla de performance. Serie 6RXSP 230-300.

Modelo de bomba	Potencia Motor		l/min m <sup>3</sup> /h	Q = Caudal														Ø Salida
	Kw	HP		200	250	300	350	400	450	500	600	700	800	900	1000	1100	1200	
			12	15	18	21	24	27	30	36	42	48	54	60	66	72	78	
6RXSP 230-2	3	4	24	23.5	23	22.5	22	21	20	18	17	15	12	9				3"
6RXSP 230-3C (4")	4	5.5	35	34	32	31	29	28	27	24	22	19	14	10				3"
6RXSP 230-3 (6")	5.5	7.5	40	39	38	37	35	34	33	29	27	23	18	14				3"
6RXSP 230-4	7.5	10	52	51	49	48	46	44	42	38	35	31	26	19				3"
6RXSP 230-5	7.5	10	65	63	61	59	57	55	53	48	44	39	32	24				3"
6RXSP 230-7	11	15	94	92	88	85	82	79	76	70	64	57	47	37				3"
6RXSP 230-8C	11	15	100	98	95	92	88	85	82	76	69	61	51	39				3"
6RXSP 230-9	15	20	120	117	114	109	105	100	96	87	80	72	61	48				3"
6RXSP 230-10	15	20	133	130	127	122	117	112	107	98	90	80	67	53				3"
6RXSP 230-11	18.5	25	146	143	138	134	128	124	118	109	99	88	74	58				3"
6RXSP 230-12	18.5	25	158	155	150	145	140	135	130	120	110	98	83	64				3"
6RXSP 230-13	22	30	174	169	165	158	152	147	141	130	119	107	89	69				3"
6RXSP 230-14	22	30	187	182	178	170	164	158	151	140	129	116	98	76				3"
6RXSP 230-15	22	30	200	195	189	183	177	169	163	150	138	124	103	81				3"
6RXSP 230-16	25.5	35	213	208	203	196	188	181	174	160	147	132	112	87				3"
6RXSP 230-17	25.5	35	227	222	215	208	200	193	186	172	158	143	121	96				3"
6RXSP 230-18	30	40	241	237	228	221	212	204	197	182	168	151	129	102				3"
6RXSP 230-19	30	40	254	248	241	233	224	216	208	193	178	160	136	107				3"
6RXSP 230-20	37	50	267	261	254	246	236	227	218	203	187	168	143	112				3"
6RXSP 230-21	37	50	281	275	267	258	248	238	230	212	195	175	149	118				3"
6RXSP 230-22	37	50	294	288	280	270	260	251	241	222	203	183	155	123				3"
6RXSP 230-23	37	50	307	301	293	283	272	262	252	232	213	191	163	130				3"
6RXSP 230-24	37	50	325	317	309	298	287	276	265	244	223	199	171	140				3"
6RXSP 300-1	2.2	3			13	12.5	12	11.5	11	10	8	7	6	5	4	2	1	4"
6RXSP 300-2A	3.7	5			24.5	23.5	23	22	21	19	17	15	13	12	10	7.5	5	4"
6RXSP 300-2	3.7	5			26	25	24	23	22	20	18	16	14	13	11	8	5	4"
6RXSP 300-3	5.5	7.5			40	39	38	37	36	32	28	26	24	21	18	14	10	4"
6RXSP 300-4	7.5	10			53	52	51	48	47	43	38	35	32	28	25	20	14	4"
6RXSP 300-5	11	15			67	66	64	62	60	55	50	46	42	38	33	27	19	4"
6RXSP 300-6	11	15			79	78	76	73	70	64	58	53	46	44	38	32	23	4"
6RXSP 300-8	15	20			106	104	101	97	94	87	80	73	67	60	53	44	33	4"
6RXSP 300-9	18.5	25			122	118	116	112	108	99	91	83	76	69	61	51	38	4"
6RXSP 300-10	18.5	25			135	132	128	125	120	111	102	95	87	78	68	57	45	4"
6RXSP 300-11	22	30			148	146	142	137	132	122	112	103	95	86	76	64	49	4"
6RXSP 300-12	22	30			162	157	153	148	143	133	122	112	103	94	83	68	53	4"
6RXSP 300-13	25.5	35			173	169	165	160	155	143	132	121	110	100	87	73	57	4"
6RXSP 300-14	25.5	35			188	184	180	175	168	156	142	130	120	109	96	80	63	4"
6RXSP 300-15	25.5	35			203	197	193	187	180	166	152	138	127	116	103	86	67	4"
6RXSP 300-16	30	40			216	211	206	200	193	178	162	148	135	123	108	92	72	4"
6RXSP 300-17	37	50			230	226	230	214	207	192	175	158	145	132	116	97	78	4"
6RXSP 300-18	37	50			243	238	233	226	218	202	185	170	155	141	126	107	83	4"
6RXSP 300-19	37	50			256	251	245	237	229	211	193	177	162	147	130	110	87	4"
6RXSP 300-20	37	50			267	263	256	248	239	220	201	184	168	153	136	115	90	4"
6RXSP 300-21	45	60			288	284	276.5	268	258	238	217	199	181	165	147	124	97	4"
6RXSP 300-22	45	60			311	307	299	289	279	257	234	215	196	178.5	159	134	105	4"
6RXSP 300-24	45	60			333	329	321	312	301	279	254	237	220	200	178	152	122	4"

NOTA. Los modelos 230-4, 230-5, 300-3 y 300-4 pueden utilizarse con motores de 4" y de 6".

Curvas de performance. Serie 6RXSP 80-90-135-150.

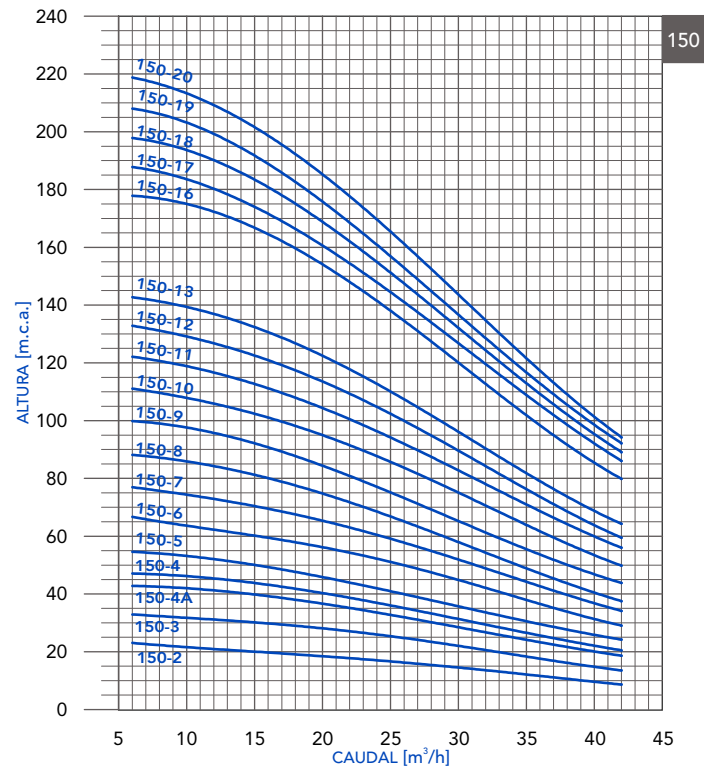
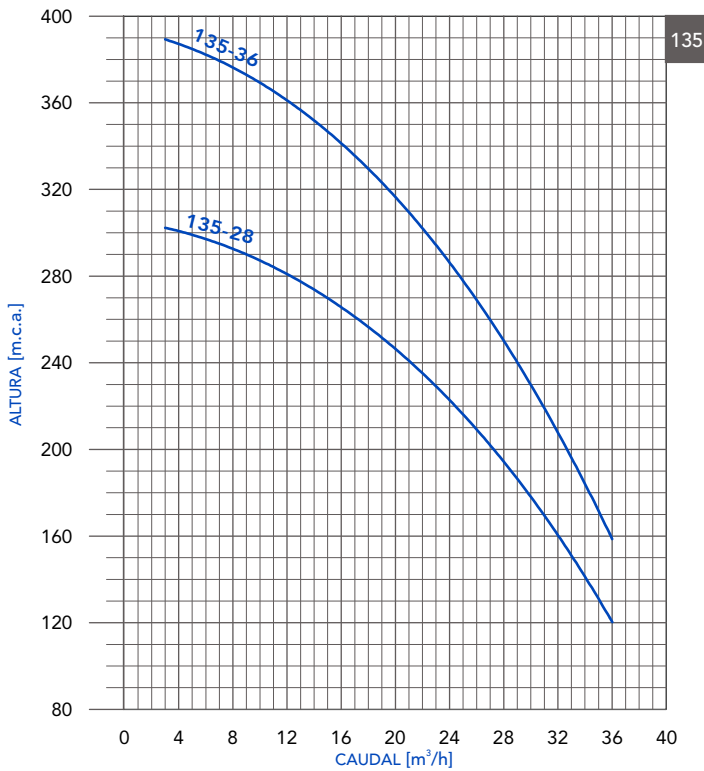
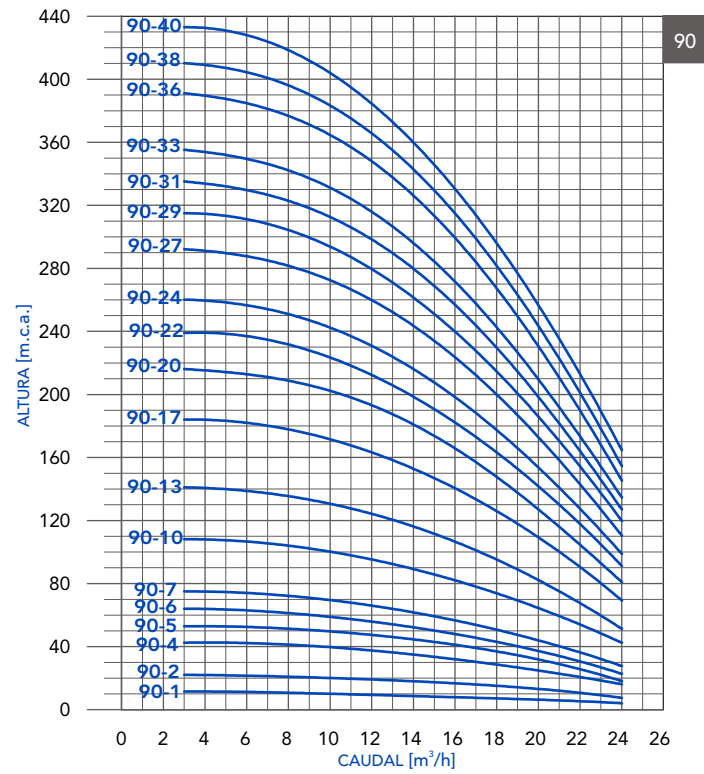
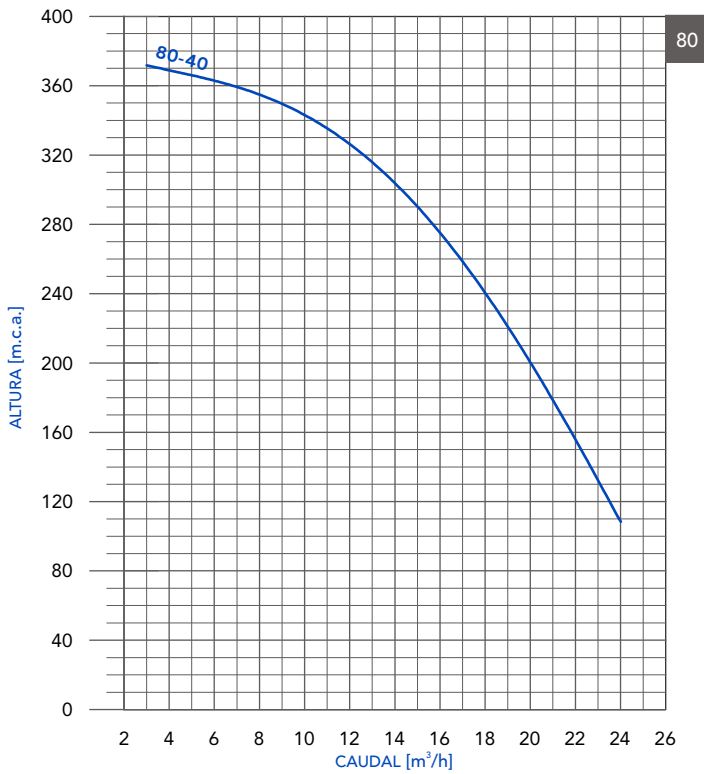

**Curvas de performance. Serie 6RXSP 150-220-230-300.**

